



VOICELINK™ III WIRELESS MICROPHONE SYSTEM

INSTALLER AND OPERATIONS MANUAL



Audio Mixer
Infrared Microphone Receiver

thank you

Congratulations on the purchase of your new TeachLogic system. You can be assured that this fulfills all specifications and was produced to very high quality control standards. TeachLogic incorporates the latest state of the art technology, employs the most advanced manufacturing methodology and uses only premium quality components to assure many years of reliable performance. We appreciate your confidence by your selection of our product. It is TeachLogic's intent to uphold that confidence by providing factory assistance and dealer support.

We hope you will take the time to review this manual to familiarize yourself with the product operation and features. This manual will help you learn to use and gain the maximum benefit of the system.

TeachLogic, LLC
Longmont, Colorado, USA
teachlogic.com

contact

If you should encounter some unresolved issue, please contact TeachLogic customer service department for further assistance.

1-760-631-7800
support@teachlogic.com
www.teachlogic.com





CAUTION

**RISK OF ELECTRIC SHOCK:
DO NOT OPEN**

Caution: To Reduce The Risk Of Electric Shock Do Not Remove Cover (Or Back)
No User-serviceable Parts Inside
Refer Servicing To Qualified Personnel



TeachLogic systems are manufactured using lead-free processes and are free of materials harmful to the environment. They conform to the most stringent new European guidelines for consumer products (RoHS).

caution

Recycle—Do not dispose rechargeable batteries in trash. Actually it is unlawful to do so in CA, NY & ME.

Contact: Earth911.com
1-800-CLEANUP

Save our resources and don't contaminate.

safety instructions

Read Instructions

All safety and operation instructions should be read before operating this TeachLogic product.

Retain Instructions

Safety and operating instructions should be kept for future reference.

Water & Moisture

This product should not be operated near water.

Heat Environment

Do not subject this product to excessive heat conditions.

Power Source

This product must be connected to an AC power source per the voltage input specified and marked on the power supply.

Power Cord Caution

Power cable should be routed clear of foot traffic and supported clear of kinking or abrasion.

Object Protection

Locate the operating unit so it will not be subjected to falling objects or water entry.

Internal Service

User should not attempt to service this product. All internal service must be accomplished by a qualified technician.

Electric Shock

Do not adapt or modify the AC power plug thus lifting the earth ground connection.

The TeachLogic logo, TEACHLOGIC and VOICELINK III are registered and non-registered trademarks of TeachLogic LLC.

VoiceLink III

owner's manual

table of contents

About Infrared	1
Product Description	2
VoiceLink III System	3
Microphone/Transmitters	4-5
Drop-in Chargers / Ceiling Sensor	6
Installation of System	7
Installation of Ceiling Sensor	8
Operation of VoiceLink III System	9
Wiring to Projector System	10-11
Troubleshooting	12
Blank Page	13
General Specifications	14
Microphone Specifications	15
Five Year Limited Warranty	16



IR transmission

The IR transmitter transmits directly to the sensor. However; due to the strength of the IR transmitter, the infrared signal will bounce off the walls, ceiling and floor for reception thus providing continuous connectivity throughout the room. Benefit: total freedom of movement within the room with no restriction of orientation.

“What’s said in the room, stays in the room”.

Infrared will not penetrate a solid surface thus preventing any transmission from going out of the room.

a brief word about infrared

Infrared is a light ray that is below the visible spectrum, just like the sound spectrum extends beyond your hearing ability. An example of infrared transmission is the remote control for your TV set. When a button is pressed, a beam of infrared light is emitted by a Light Emitting Diode (LED) from the remote control. It is detected by a receiving diode in your TV set. When you press a certain command on your control, the internal electronics cause the infrared light to flicker in a programmed sequential pattern (called modulating the light beam). The modulated infrared beam is detected by the receiving diode and is electronically decoded. The decoded signal activates the circuitry to perform the command function on your TV set.

So how does this apply to the infrared communication system you are about to start using? The microphone/transmitter has several Light Emitting Diodes (LED) that emit infrared light beams to the sensor located in the corner of the room. Now when you talk into the microphone, the microphone element modulates the light beam, causing it to flicker in sync with your speech. The sensor detects the sequential signal and the electronic circuitry in the VoiceLink III converts that sequential signal into a line level analog audio signal. Now that audio signal can be fed into an amplifier. The amplifier magnifies the electronic signal and sends it to the speakers. This causes the speaker cone to move in sync with your voice. The speaker replicates your voice and disperses your voice evenly throughout the room.

product description

The VoiceLink III is an infrared wireless microphone system that can be added to any sound system. It can be a supplement to an existing multi-media system to expand it's utilization to provide voice reinforcement.

The addition of a VoiceLink III system to your multi-media system will transform your classroom sound system into a totally hands free voice re-enforcement system, resulting in reduced voice fatigue, enhanced student listening and improved student learning. The wireless function permits 360° connectivity throughout the classroom regardless of body position or orientation.

The system is comprised of an infrared detecting sensor(s) installed in the ceiling. The sensor collects the IR wireless signal from the microphone/transmitter and sends a composite signal to the receiver. The receiver transforms the composite signal into an analog audio signal which is fed to the multi-media amplifier. The amplifier powers the speakers for even voice reinforcement throughout the room.

The microphone / transmitter can be the Sapphire or Handheld. The rechargeable batteries will provide 6 – 8 hours of service per charge. The drop-in charger will recharge the batteries overnight, ready for another day's use.

Reliable
performance.
Use with
confidence.

VoiceLink III system

The VoiceLink III system is comprised of a microphone / transmitter, either the Sapphire (IRT-55), or Handheld (IRH-35) for voice transmission to a ceiling sensor (ICS-55) that sends the signal to the receiver / mixer (IR-255). The receiver processes the signal and produces an analog signal of your voice for input to an amplified sound system.

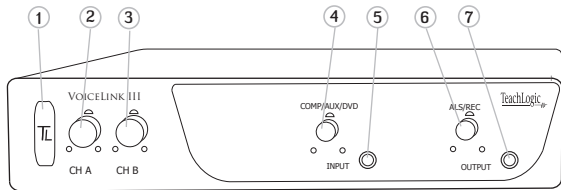

front of IR-255 receiver/mixer

- | | |
|----------------------------------|---------------------------|
| 1 Power / Mute Button | 5 Auxiliary Input (3.5mm) |
| 2 CH A Microphone Volume Control | 6 ALS/REC Volume Control |
| 3 CH B Microphone Volume Control | 7 ALS/REC Output (3.5mm) |
| 4 Auxiliary Volume Control | |

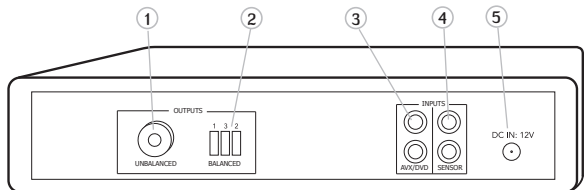

back of IR-255 receiver/mixer

- | | |
|--|---------------------------|
| 1 Unbalanced Line Level Output (1/4" phone) | 3 Dual Mono Inputs (RCA) |
| 2 Balanced Line Level Output (3-pin Phoenix Connector) | 4 Two Sensor Inputs (RCA) |
| | 5 Power Input: 12VDC |

infrared microphone/transmitters

The infrared microphone/transmitter is comprised of a microphone input, signal processing circuits and several emitting diodes that transmit the vocal signal to the sensor.

The microphone/transmitter can be the Sapphire or Handheld. The rechargeable batteries will provide 6–8 hours of service per charge. Place the microphone/transmitter in the charger for overnight charge and it will be ready for another day's use.

The drop-in battery chargers are specifically designed to recharge lithium & NiMH batteries at an optimum rate for maximum operating capacity and extended service life. Charger will automatically start charging the batteries upon insertion and will shift to a maintenance charge when batteries are fully charged.



features

- Elegant design
- Only 1.4 oz. including battery
- Long life "Lithium ion" battery
- Rechargeable via USB cable to computer
- Battery level indicator – Back light under power switch
- Momentary mute button, backlight blinks in mute mode
- Push "on/off" power
- Channel "A" or "B" selectable
- Three level microphone volume switch (low, medium, high)
- Auxiliary input (3.5mm)
- Wear with a lanyard or slide directly on neckline collar

(IRT-55) sapphire transmitter

The Sapphire's vocal clarity is unsurpassed. Its high level output is achieved by the unidirectional (Cardioid) microphone and a unique free air suspension system. With a built-in breath filter, the Sapphire can function as a pass around hand mic.

The strategic alignment of the emitting diodes assures reliable connectivity throughout the room without static or drop out.

With a tap on the power button, the microphone is muted for private conversation—tap again to restore to normal operation. The auxiliary input allows wireless playback of your iPod™ through the Sapphire. A three position slide switch provides selection of low, medium, or high microphone sensitivity.



features

- Condenser microphone element
- Power “on/off” switch
- Battery level indicator—LED
- Channel “A” or “B” selectable
- 10 high-power emitting diodes
- Diodes at top and bottom of handle for increased Coverage (2 Top aimed out, 6 Bottom 360°, 2 Bottom aimed down)
- 360° IR radiation for assured connectivity
- Two “AA”, Duracell, rechargeable NiMH batteries



IRH-35 handheld transmitter

The Handheld Microphone Transmitter (IRH-35) is most applicable for student use or direct presentation. It has an “on/off” switch and a battery level indicator LED; Green=useable charge, Red=low battery. The transmitter has 10 emitting diodes: 8 around the bottom of the handle, and 2 toward the top of the handle. The metal housing provides low handling noise and insures durable longevity.

BRC-60 drop-in battery charger

This stylish desktop drop-in charging station makes it convenient and easy to recharge both Sapphire Pendant and Handheld Microphones. Charge one IRH-35 handheld transmitter and up to two IRT-55 Sapphire transmitters simultaneously. Charging indicator lights illuminate Red when charging, and Green when fully charged. The “TL” logo illuminates Blue when plugged in.



power “on” LED

Green light indicates that the sensor is receiving power from the receiver.

ICS-55 ceiling sensor

The ceiling sensor is the preferred infrared sensor for optimum performance. This is the unit that needs to be installed on the ceiling. It comes with a mounting/support bracket and 50 feet of plenum rated cable with RCA connector on each end. The ideal location for the dome sensor would be in the center of the ceiling. This will provide a clear signal path for the IR transmission from the transmitter to the dome sensor without obstruction. In addition, you will have 360° coverage and will minimize the transmission distance for more reliable performance. It collects the infrared transmission signal via 6 large detecting diodes.

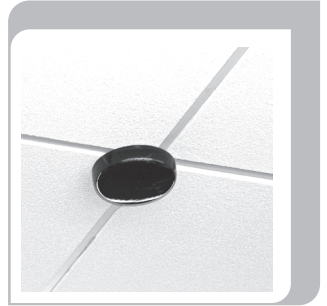

sensor cable

A Cable connects the sensor to the receiver. The cable is dual-shielded with a male RCA connector on each end and is plenum rated.



installation of system

Location of receiver is primarily determined by user accessibility, location of sound system and availability of an electrical outlet. Location of the sensor and routing of the sensor cable is a more critical issue.

location and Installation of receiver

Since the VoiceLink III is a supplement to an existing power amplifier system, you will want to locate the receiver near the power amplifier to minimize audio cable length from receiver to sound system.

Connect the output of the receiver to the line input of the sound system.

- Unbalanced: Use a shielded cable with 1/4" phone connector

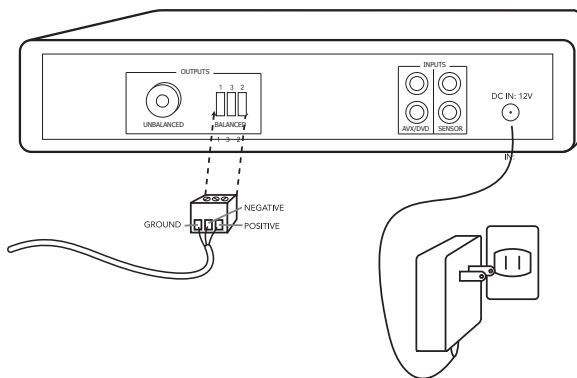

Plug power supply into AC outlet.
Plug power cable into receiver.

installation of ICS-55 ceiling sensor

The ideal location for the ceiling sensor is in the center of the ceiling. This will provide a clear signal path for the IR transmission from the transmitter to the dome sensor without obstruction. In addition, you will have 360° coverage and will minimize the transmission distance for more reliable performance.

Attaching the infrared ceiling sensor

Installation 1 ----- Attach to T-bar Rail

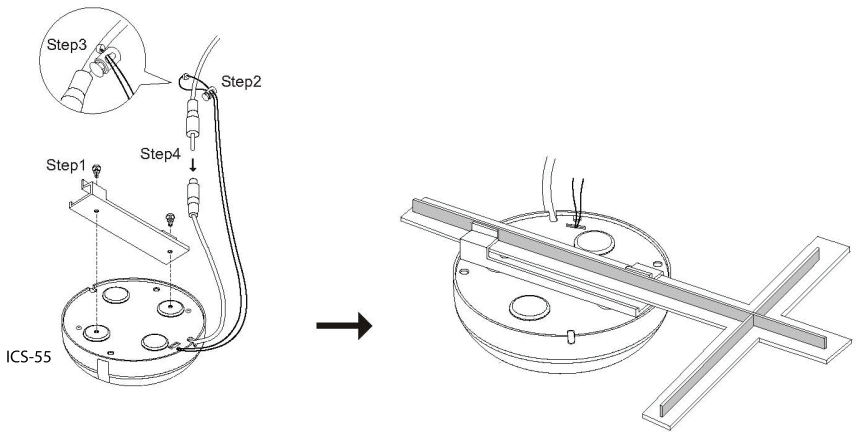

Installation 2 ----- Attach to wood surface

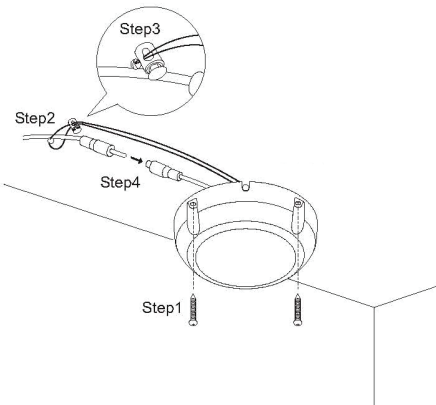

Installation 3 ----- Attach to concrete surface

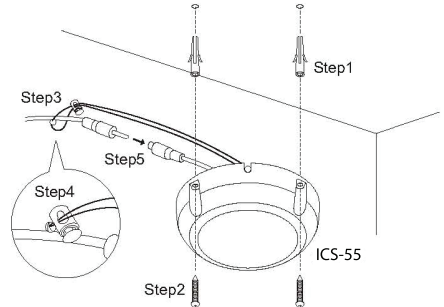

operation of VoiceLink III system

Now that the system is installed and connected, we are ready to turn the system “ON” and test its performance. The testing will be done using an IR transmitter (Sapphire or Handheld) to confirm good connectivity and quality audio.

system operation

- Turn the VoiceLink III “ON”, Blue LED will light
- Confirm power to sensor, Green LED on edge of sensor
- Set volume of Ch A volume control to mid scale (12 o'clock)
- Using a Sapphire Transmitter microphone select channel “A” (Mics are shipped in channel A)
Sapphire: “A-B” switch, remove battery cover on back, under battery.
Handheld: Unscrew barrel and remove.
Note “A-B” switch on side of battery holder.
- Turn volume control on Sapphire transmitter to mid level between “HI” and “LOW”
- Switch transmitter “on”
- Observe power LED (Blue) - use fully charged battery only
- Observe signal presence LED (Orange) on receiver adjacent to “Mic” volume control
- Stand under or in front of a speaker
- Slowly adjust “Ch A” volume on VoiceLink III while talking into microphone
- Adjust to desired listening level.
CAUTION: Beware of feedback
- Walk around the room while talking into microphone to confirm good connectivity

Upon completion of performance test, the installation is complete.

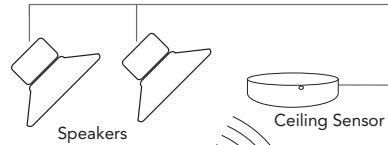

projector system setup

How to Interface VoiceLink III with a Video Projector and incorporate the Projector's Remote Control

- With the ceiling sensor installed, connect it to the VoiceLink III sensor input
- Locate VoiceLink III near projector and connect to AC power
- Connect an audio cable with 3.5mm connectors from projector audio output to VoiceLink III COMP/AUX/DVD Input (front panel)
- Connect VoiceLink III output to power amplifier
 - Shielded audio cable with RCA phono from unbalanced output to amplifier input
 - Shielded two-conductor cable connected per balanced output per page 11
- Turn "on" VoiceLink III, Power Amplifier, and Video Projector
- Set "COMP/AUX/DVD IN" control on VoiceLink III to 2 o'clock position
- Set Power Amp volume (if applicable) mid scale
- With microphone turned "on", speak and adjust microphone volume using "CH A" or "CH B" volume control on VoiceLink III
- With an Auxiliary program turned "on" and plugged into the projector, adjust the auxiliary volume with the remote control
- Some adjusting of the VoiceLink III (COMP/AUX/DVD) and amplifier volume may be required
- Once auxiliary volume is optimized, readjust microphone volume using "CH A" or "CH B" volume control
- System is now ready to use with remote control of AUX inputs and consistent Mic volume (Mic volume does not change with remote volume control)

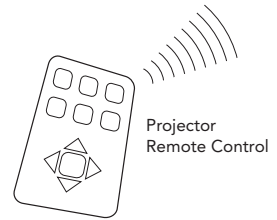

note

Microphone volume is not affected by the remote control of the auxiliary inputs.

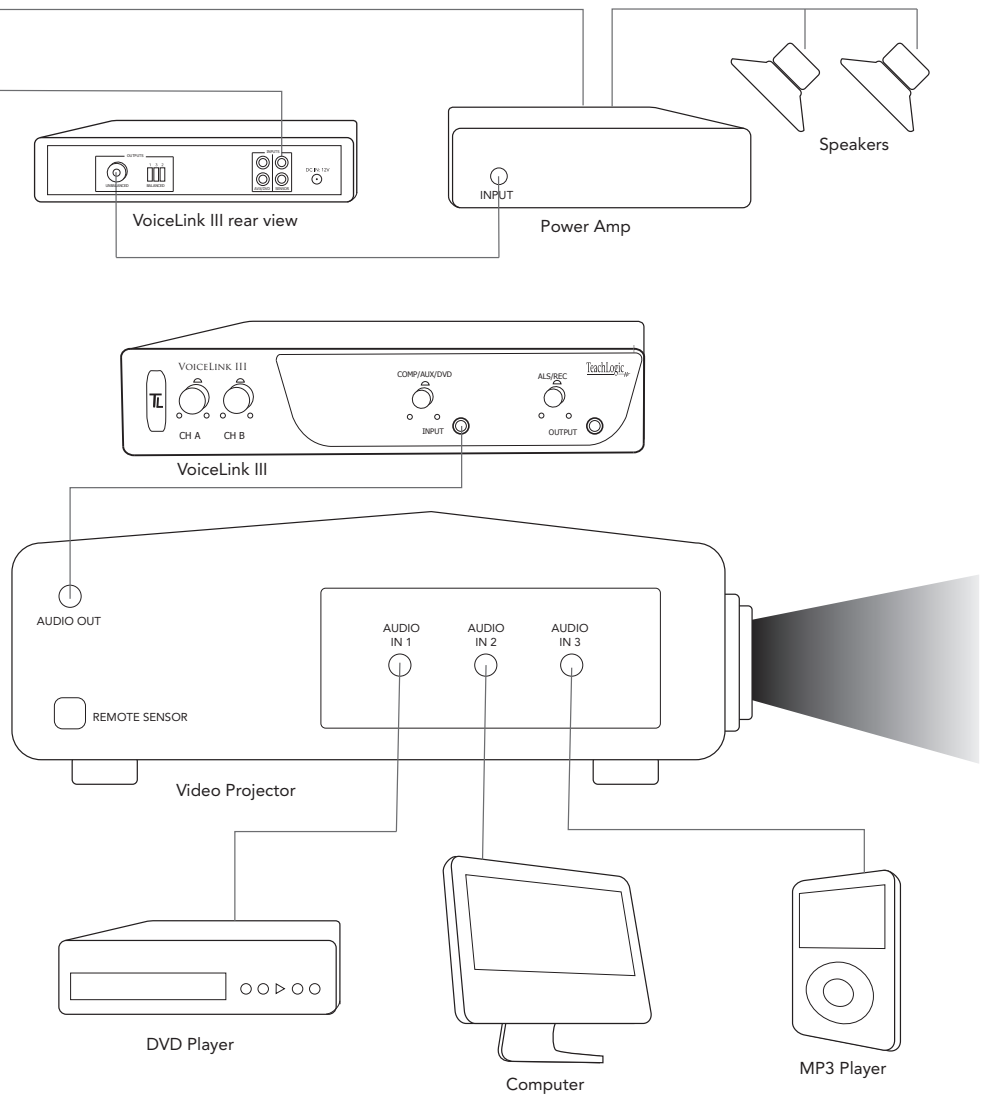

VoiceLink III

owner's manual

VoiceLink III (IR-255) specs.

Receiver Input	Infrared FM
Modulation	FM Wide-band
Reception Frequencies	Ch. A: 2.08 MHz, Ch. B: 2.54 MHz
Infrared Wavelength	850 nm
Tone Signal	Ch. A: 32.768 KHz
De-emphasis	50 μ s
Frequency Response	50 Hz, -13KHz, \pm 3dB
S/N Ratio	>65 dB
THD	<1% @1KHz
Nominal Deviation	\pm 10 KHz
Maximum Deviation	\pm 25 KHz
External Sensor Input	Two, RCA
Computer/Aux Input	3.5mm with Gain Control, Front Panel
Line Output	3.5mm with Gain Control, Front Panel Balanced 3 pin Phoenix 1/4" Unbalanced Line Out, Rear Panel
Power Supply	12VDC / 0.6A / 7.2W
Dimensions	8 3/8" W x 1 3/4" H x 7" D
Weight	1 lb. 7oz.
Enclosure	ABS / Aluminum

general transmitter specs.

Transmission Carrier	Infrared FM
Transmission Frequencies Channel Switchable A or B	2.08 MHz & 2.54 MHz
Modulation	Field Switchable FM Wide-Band
Pilotone Frequency	32.768 KHz
Peak Deviation	\pm 25KHz
Operating Range	1600 Ft ² , 60 Ft.
Power Switch (Slide)	On/Off
Battery Charge Level (LED)	Green, (Useable Charge) Red, (Needs Charging)
Battery Life	Approx. 7 Hr./Charge
External Battery Contact	Charger Connection

power supply (AC-10) specs.

Type	Regulated Switching Power Supply
Input Voltage	100-240 volts AC, 47-63Hz
Output Voltage	12.0 volts DC, 0.6A
Power Output	7.2 watts Max.

Sapphire transmitter (IRT-55) specs.

Transmitting Diodes	6
Operating Range	1,600 Ft ² . 60 Ft. Line of Sight
Battery Discharge Indicator	
Blue	Full
Purple	Medium
Red	Low
Flashing Red	Very Low Battery
Battery Used	Lithium-ion (3.7V / 620mAh)
Battery Life	Approx. 8-9 Hrs/Charge
External Power Charger	DC +5V, Micro USB Connector
Transmission Angle	Conical
User Controls	
Power Switch (push)	On/Off
Mute Switch (push)	On/Off
Mic Switch (3 position)	+6db, Normal, -3db
Aux. Vol./Gain	Increase, Decrease
Channel Select	(A or B) in battery compartment
External Aux. Input	3.5mm Stereo Line Level
Dimensions	5/8" H x 1 1/4" W x 3/4" D
Weight	1.4 oz. Including battery

3

Handheld transmitter (IRH-35) specs.

2 Channel Switchable	Field Switchable
Transmitting Diodes	Ten
Modulation	FM Wide-Band
Pilotone Frequency	32.768 KHz
Peak Deviation	± 25KHz
Operating Range	1600 Ft ² . 60 Ft.
Power Switch (Slide)	On/Off
Battery Charge Level (LED)	Green (Useable Charge) Red (Needs Charging)
Battery Life	Approx. 7 Hr./Charge
Dimensions	2 1/8" Dia. Head, 1 7/16" Dia. Body, 9 5/8" H
Weight	10.3 oz. w/ Battery

drop-in battery charger (BRC-60) spec

Charging Port	2 Sapphire, i Handheld
Red LED	Battery being charged
Green LED	Battery fully charged
Power Supply	5 VDC, 1 Amp
Dimensions	6 3/8" L x 3 3/8" W x 3 3/8" H
Weight	6.3 oz

troubleshooting

Problem	Solution
System is turned “on” but there is no sound	<ul style="list-style-type: none"> • Verify AC power; the Red LED lights when turned “on” • Check if system has been unplugged • Check circuit breaker • Call maintenance for assistance
System has power but no sound	<ul style="list-style-type: none"> • Turn “on” microphone/transmitter • Check for IR transmission, Signal presence (Orange LED) • Check the Yellow LED in the sensor • If sensor LED is not lit <ul style="list-style-type: none"> • Sensor has been disconnected • Power output to sensor has failed (Receiver/amplifier needs to be replaced)
Voice is distorted and/or signal drop-out occurs	<ul style="list-style-type: none"> • Check the charge on your batteries • Verify power switch in battery compartment is in “Hi” position (Body-Pack transmitter) • Verify that the diodes on transmitter or sensor are not being covered • Obstruction between transmitter and sensor

contact

If your problem persists and this guide has not resolved the issue, call our customer service department for additional assistance. (760) 631-7800

five year limited warranty

TeachLogic IR products are guaranteed to be free of defects in workmanship or material for a period of five (5) years from date of original purchase, subject to the following conditions:

1. Warranty excludes defects caused by normal use and wear, any abuse, or failure to use the product in accordance per instructions.
2. Warranty is void if damage occurred because of misuse, or attempted repair or modification by unauthorized personnel.
3. Warranty on batteries is for two (2) years.
4. Warranty does not extend to finish.
5. All warranty service will be provided by TeachLogic or authorized service center
6. Warranty is made to the original purchaser and may not be transferred to another user.
7. Warranty service rendered will be on a repair or replacement basis, whichever TeachLogic deems to be most prudent for customer satisfaction and economic feasibility.

TeachLogic will only accept warranty shipments accompanied by Return Authorization Number previously assigned by TeachLogic personnel. Advance warranty replacements will be made per the discretion of TeachLogic personnel.

TeachLogic will pay return shipping cost on all warranty repairs or replacements.

contact

TeachLogic
Customer Service Dept.

1-760-631-7800
support@teachlogic.com
www.teachlogic.com



☎ 1-760-631-7800

✉ support@teachlogic.com

🌐 teachlogic.com

P/N UMM-255
rev003 20191216